



Type: _____

Model: _____

KINGSTON

MR16 Well Light Fixture



- SKU: 917062
- 12V AC/DC
- Triple aperture solid cast brass faceplate
- Antique Bronze finish
- Corrosion resistant non-metallic canister
- Specification grade, beryllium copper socket
- Clear lens
- Anti-moisture connections
- Powder-coated color options available
- 60" 18AWG wire lead
- IP65 and ETL rated
- Lifetime warranty

DESCRIPTION

The Kingston is a sealed well light that uses an MR16 lamp. The socket is mounted on an adjustable gimbal so the lamp's angle can be adjusted. The top is thick solid cast brass. Thick rubber gasket between the top and body of the well light for a watertight seal. The lower canister is completely sealed. The round lead wire uses a waterproof pressure fitting. We offer a variety of solid cast brass top options for any in ground well lighting application. Install it with our Heavy duty PVC Well Light sleeve which provides a durable housing for all Brass In-Ground fixtures.

DIMENSIONS

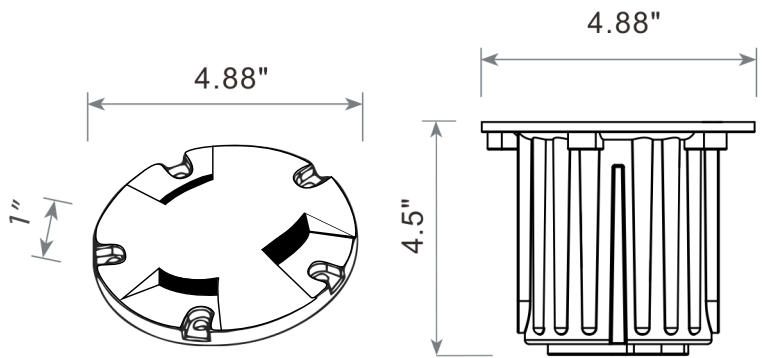

IP65